

**Functional Test Data**

Output bit	Function	Input bit	Function
2	not used	2	not used
1	not used	1	opto input 1 = $\geq 4v$ 0 = $\leq 1v$
0	operates relay 1 = on 0 = off	0	monitored input 0 = quiescent 1 = input received

For further information on protocol bit usage refer to the Input/Output Unit PIN sheet, PP2092.

**Troubleshooting**

Before investigating individual units for faults, it is very important to check that the system wiring is fault free. Earth faults on a data loop or any ancillary zone wiring may cause communication errors. Many fault conditions are the result of simple wiring errors. Check all connections to the unit and make sure that the correct value resistors are fitted where necessary.

**Fault finding**

Problem	Possible Cause
No response or missing	Incorrect address setting Incorrect loop wiring
Fault condition reported	Incorrect input wiring
Relay fails to operate	Incorrect wiring Control panel has incorrect cause and effect programming
Relay energised continuously	Incorrect loop wiring Incorrect address setting
Analogue value unstable	Dual address Loop data fault, data corruption
Constant Alarm	Incorrect wiring Incorrect end-of-line resistor fitted Incompatible control panel software
Isolator LED on	Short-circuit on loop wiring Wiring reverse polarity Too many devices between isolators



## Input/Output Unit Installation Guide

**General**

The Input/Output Unit, part no 55000-847, which is a loop-powered device, provides a volt-free, double pole, change-over relay output, a single, monitored switch input and an unmonitored, polarised opto-coupled input. It is supplied with a backbox for surface mounting and has an integral isolator as standard.

*Note: The Input/Output Unit is not designed for outdoor use unless it is mounted in a suitable weatherproof enclosure.*

**Installation**

1. Mount the backbox as required and install all cables for termination. Ensure that earth continuity is maintained.
2. Remove the cover plate (if secured) from the Input/Output Unit assembly by inserting the blade of a terminal screwdriver into each of the four securing clips in turn, gently prising the outer edge of the cover plate over the clips underneath. **DO NOT USE EXCESSIVE FORCE.**
3. Terminate all cables.
4. Gently push the completed assembly towards the back box until the mounting holes are aligned and secure with the two mounting screws provided. **DO NOT OVERTIGHTEN.**
5. Set the address of the unit as shown on page 3.
6. Finally, when commissioning is complete, fit the cover plate by placing it in position, observing the correct orientation (LEDs on the PCB must be aligned with viewing holes). Apply pressure to the cover plate until all four clips are holding it in position.

## Wiring Details

All wiring terminals will accept solid or stranded cables up to 2.5mm<sup>2</sup>

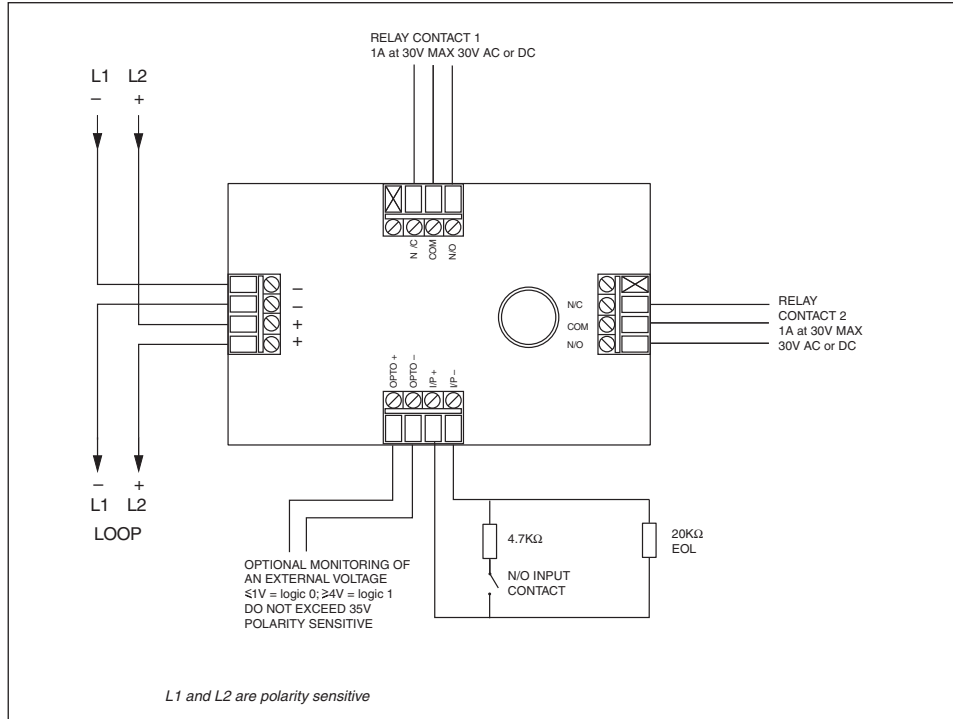

## Current consumption at 28V (no protocol)

### LED Enabled

switch-on surge 200ms	5mA
quiescent, 20kΩ EOL fitted	1mA
switch input closed 'switch closed' LED on	2.5mA
any other condition (max 2 LEDs on)	3mA

### LED Disabled

switch-on surge 200ms	4mA
quiescent, 20kΩ EOL fitted	1mA
switch input closed	1.5mA
any other condition	2mA

For a full technical specification of the Input/Output Unit, please refer to the Input/Output Unit PIN Sheet, PP2092. For further information on isolators, please refer to PP2090.

## Address Setting

The address of the Input/Output Unit is set using the lower seven segments of the DIL switch. Each segment of the switch must be set to "0" or "1", using a small screwdriver or similar tool. A complete list of address settings is shown below.

addr	DIL switch setting 1234567	addr	DIL switch setting 1234567	addr	DIL switch setting 1234567	addr	DIL switch setting 1234567	addr	DIL switch setting 1234567
1	1000000	11	1101000	21	1010100	31	1111100	41	1001010
2	0100000	12	0011000	22	0110100	32	0000010	42	0101010
3	1100000	13	1011000	23	1110100	33	1000010	43	1101010
4	0010000	14	0111000	24	0001100	34	0100010	44	0011010
5	1010000	15	1111000	25	1001100	35	1100010	45	1011010
6	0110000	16	0000100	26	0101100	36	0010010	46	0111010
7	1110000	17	1000100	27	1101100	37	1010010	47	1111010
8	0001000	18	0100100	28	0011100	38	0110010	48	0000110
9	1001000	19	1100100	29	1011100	39	1110010	49	1000110
10	0101000	20	0010100	30	0111100	40	0001010	50	0100110
51	1100110	61	1011110	71	1110001	81	1000101	91	1101101
52	0010110	62	0111110	72	0001001	82	0100101	92	0011101
53	1010110	63	1111110	73	1001001	83	1100101	93	1011101
54	0110110	64	0000001	74	0101001	84	0010101	94	0111101
55	1110110	65	1000001	75	1101001	85	1010101	95	1111101
56	0001110	66	0100001	76	0011001	86	0110101	96	0000011
57	1001110	67	1100001	77	1011001	87	1110101	97	1000011
58	0101110	68	0010001	78	0111001	88	0001101	98	0100011
59	1101110	69	1010001	79	1111001	89	1001101	99	1100011
60	0011110	70	0110001	80	0000101	90	0101101	100	0010011
101	1010011	111	1111011	121	1001111				
102	0110011	112	0000111	122	0101111				
103	1110011	113	1000111	123	1101111				
104	0001011	114	0100111	124	0011111				
105	1001011	115	1100111	125	1011111				
106	0101011	116	0010111	126	0111111				
107	1101011	117	1010111						
108	0011011	118	0110111						
109	1011011	119	1110111						
110	0111011	120	0001111						

## Commissioning

It is important that the Input/Output Unit be fully tested after installation. An XP95 Test Set, part no 55000-870, may be used to carry out functional testing of individual units. It can also be used to perform data integrity tests of an entire loop.

Note: If this product has been subjected to excessive shock during transportation, it may be received with the relay contacts in the 'set' position. Reset the relay by subjecting it to one operating cycle before commissioning the system.

## LED Indicators

⊙ Isolator	illuminated yellow when a short circuit on the loop causes the integral isolator to operate
⊙ Relay On	illuminated red when relay is energised
⊙ Switch Closed	illuminated red when monitored field contact is activated
⊙ Fault	illuminated yellow when input is open or short circuit

The use of all the LEDs, with the exception of the isolator LED, can be disabled by setting the 'LED ENABLE' segment of the DIL switch to '0'.